



Equipment for the Foodservice Industry

value + quality + service

Cube Ice Machine

IM-500



IM-500

Features

Features:

- Convenient, built-in scoop holder
- Easily removable baffle, no tools required for cleaning
- Light weight
- Corrosion resistant
- Ice scoop included
- Makes full cube sized ice

Warranty:

- One year parts and labour
- Specifications subject to change without notice



IM-500

Specifications

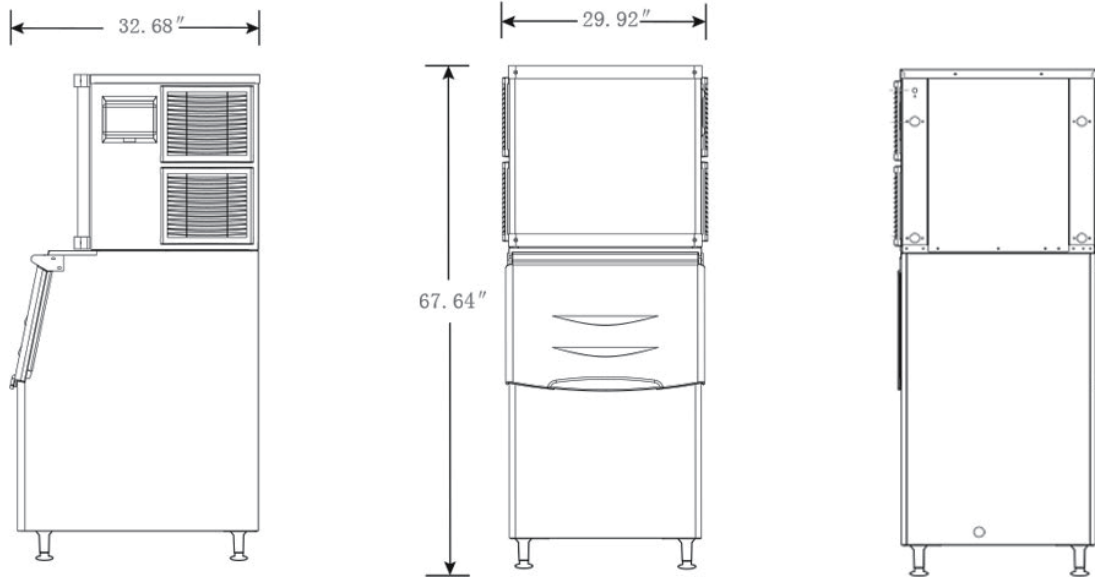

| Model | Refrigerant | Dimension (mm) (inch) | | | Condenser Unit | Voltage (V/Hz) | Power (W) | Bin Capacity (KG) (LBS) | Output LB/24hr (KG) (LBS) | Net Weight (KG) (LBS) |
|--------|-------------|-----------------------------|------|------|-------------------|-------------------|--------------|----------------------------------|------------------------------------|-----------------------------|
| | | L | D | H | | | | | | |
| IM-500 | R290 | 760 | 830 | 1718 | Air | 110/60 | 1113 | 170 | 225 | 66 |
| | | 30 | 32.7 | 67.6 | | | | 375 | 500 | 145 |