



Equipment for the Foodservice Industry
value + quality + service

Heat Cabinet

HCGD-9



HCGD-9

Features

Features:

- The fully transparent polycarbonate door with an opening degree larger than 90 degrees is convenient for loading food and can view the food storage situation in real time.
- Strong magnetic door handle ensures that the door seal is close to the cabinet to prevent heat loss.
- Removable part tray holder, removable drawer type control module for easy internal cleaning.
- The product is equipped with humidified water plate, which can prevent the water loss of food and make the taste better.
- The product is filled with environmental protection foaming material to prevent heat loss, energy saving and environmental protection.
- Supply air heating mode, rapid heating, uniform temperature in the cabinet, ensure food color.
- Circular digital temperature display, easy to view the temperature in the cabinet.
- Temperature and humidity dual control technology, adjust to the best temperature and humidity, extend food preservation and storage time.
- Includes power cord but no plug end.
- Specifications subject to change without notice



HCGD-9

Specifications

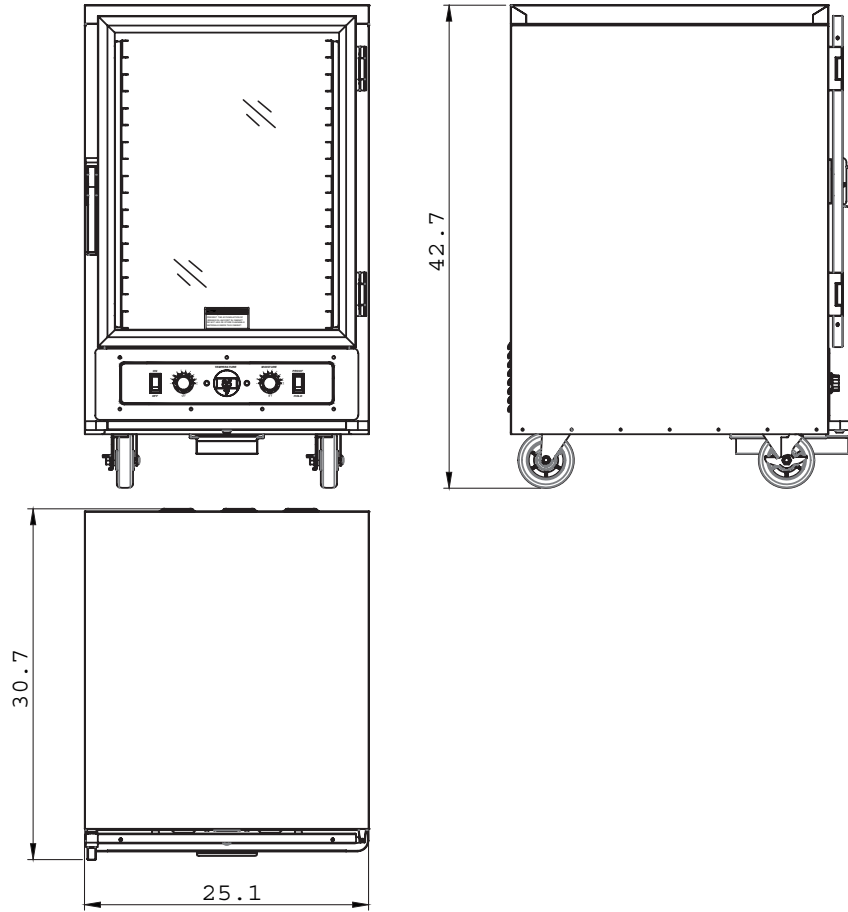

Model	Dimension (mm / inch)			Power (W)	Voltage (V)	Frequency (Hz)	Net Weight (kg / lbs)	Gross Weight (kg/lbs)	Pans can be held (18"x26")
	L	D	H						
HCGD-9	638	780	1085	2,000	120	60	56	76	9
	25.1	30.7	42.7						